

CAULKING MATERIAL

For fixing the knives in the cylinder grooves we recommend the use of copper. Copper has the quality of being soft, tough and malleable in its annealed form, while its hardness is considerably increased by cold-forming. During the fitting of the blades the cold-hardening is achieved by forcing the copper into the grooves, and in particular by the caulking action. Used copper does not meet the reblading requirements and should never be used because dimensional accuracy and stability can no longer be guaranteed.

The dimensions of the copper insert can be derived from those of the grooves:

copper height = groove depth + 2 mm

copper width = groove width - blade width
(+ 0,1 mm if necessary)

Example:

groove width	5 mm
groove depth	6 mm
blade thickness	2,1 mm (at blade foot)
copper dimensions:	2,9 mm wide x 8 mm high

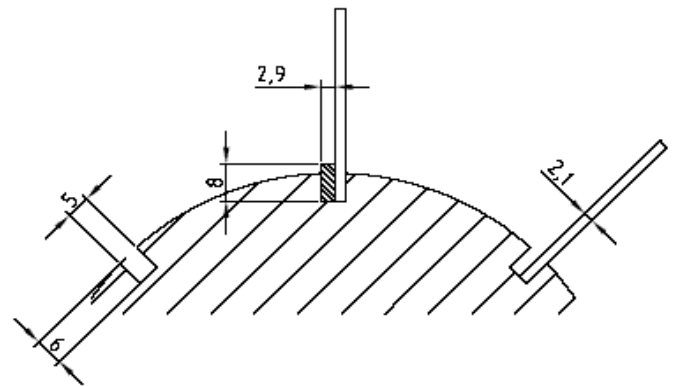

After several reblading operations on the same cylinder it is recommended to increase the copper width slightly. Mostly it is sufficient to increase width by one decimillimeter (0,1 mm). In our example the copper measurements would become 3,0 mm wide x 8,0 mm high. In order to facilitate easier entry of the caulking material into the grooves, wedge-shaped copper strip at its upper edge has to be increased by 0,2 mm, whereas the width at the bottom edge has to be reduced by 0,2 mm.

If wedge-shaped copper is used, the correct dimensions for our example would be:

copper dimensions 2,7 mm x 3,1 mm x 8 mm.

